

- 5 - OFF MARK OR-(A6-A8) - AS DRAWN
- 1 - OFF MARK OR-(A8-A9) - AS DRAWN
- 1 - OFF MARK OR-(A8-A9) - OPP. HAND
- 1 - OFF MARK OR-(H6-H9) - AS DRAWN
- 6 - OFF MARK OR-(H6-H9) - OPP. HAND

- 1 - OFF MARK OR-(E4-E6) - AS DRAWN
- 6 - OFF MARK OR-(E4-E6) - OPP. HAND
- 1 - OFF MARK OR-(K2-K4) - AS DRAWN
- 1 - OFF MARK OR-(R2-R3) - AS DRAWN
- 1 - OFF MARK OR-(R2-R3) - OPP. HAND
- 3 - OFF MARK OR-(R3-R5) - AS DRAWN
- 4 - OFF MARK OR-(R5-R7) - AS DRAWN
- 1 - OFF MARK OR-(S7-S11) - OPP. HAND
- 8 - OFF MARK OR-(S7-S11) - AS DRAWN
- 1 - OFF MARK OR-(L7-L11) - AS DRAWN
- 8 - OFF MARK OR-(L7-L11) - OPP. HAND

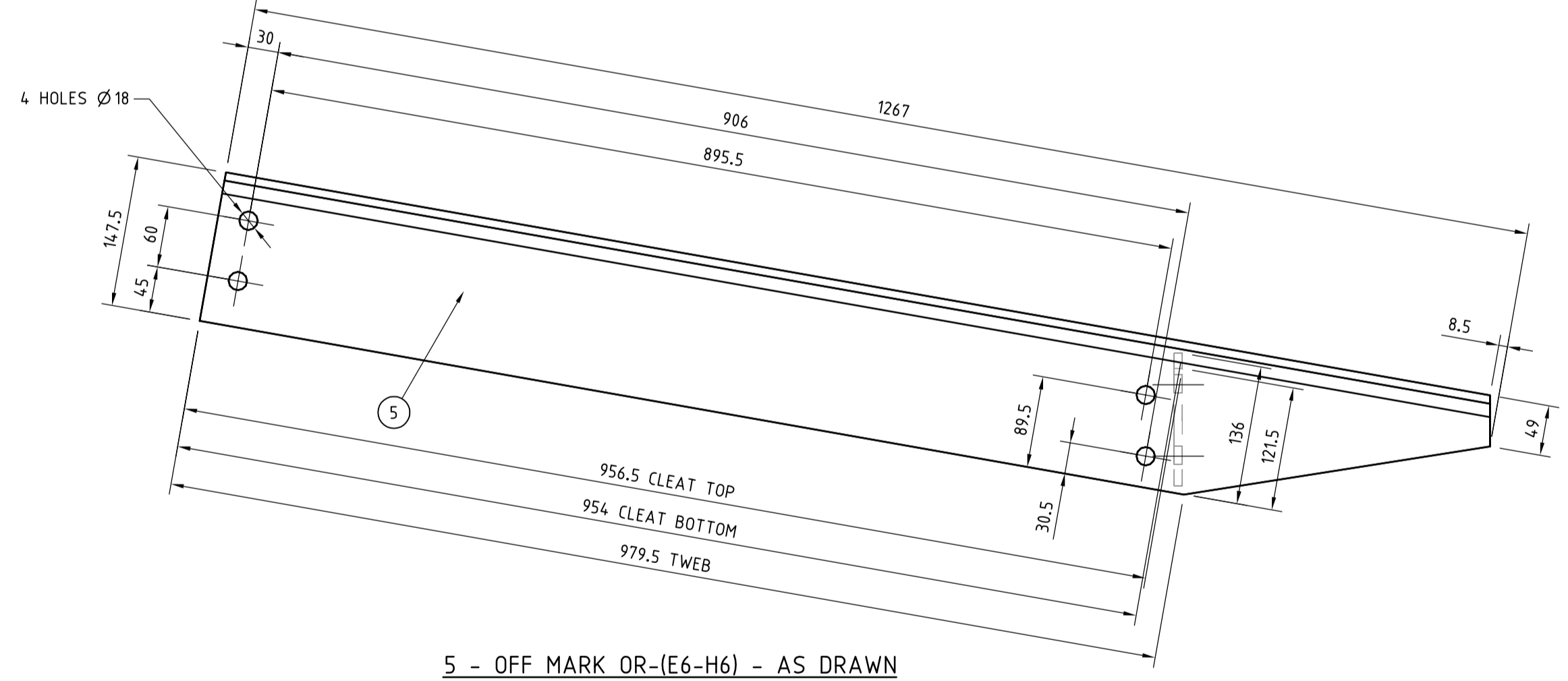
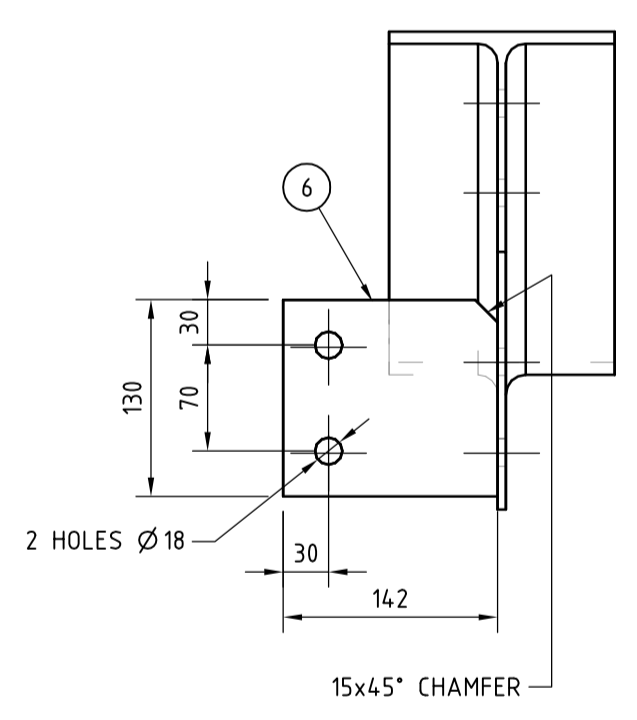
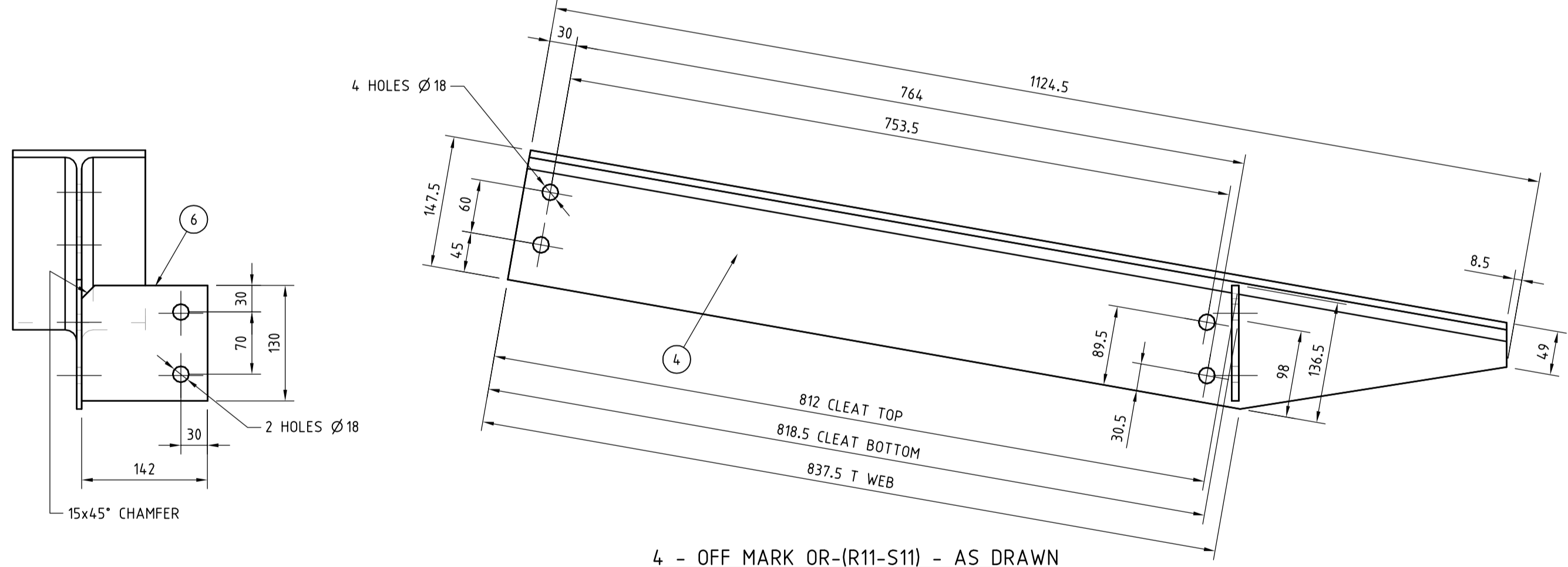
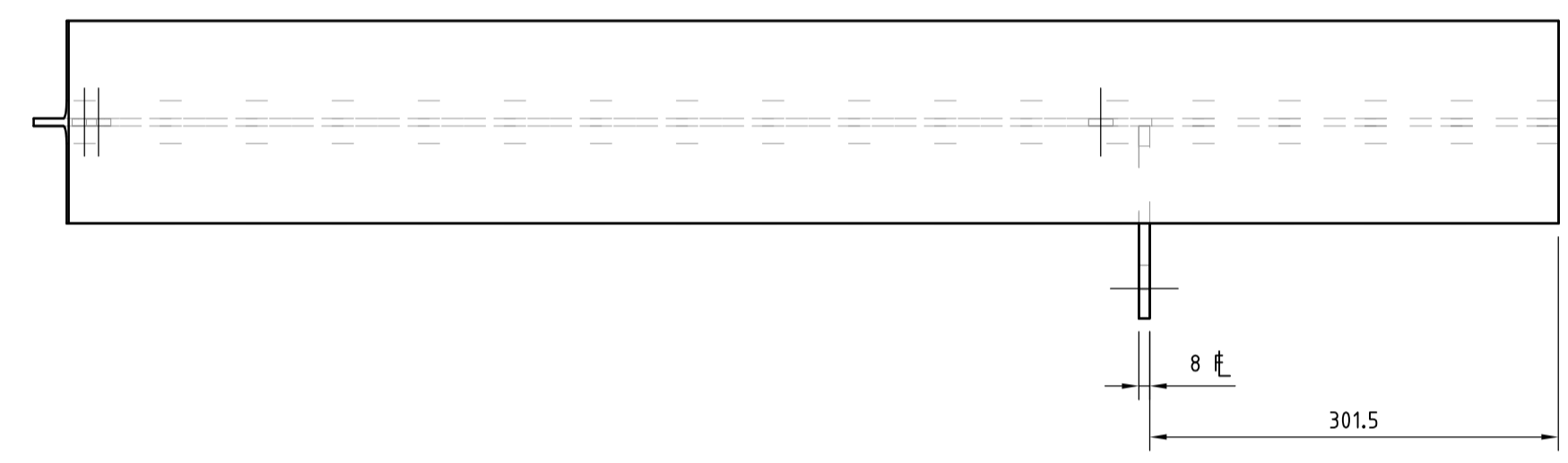
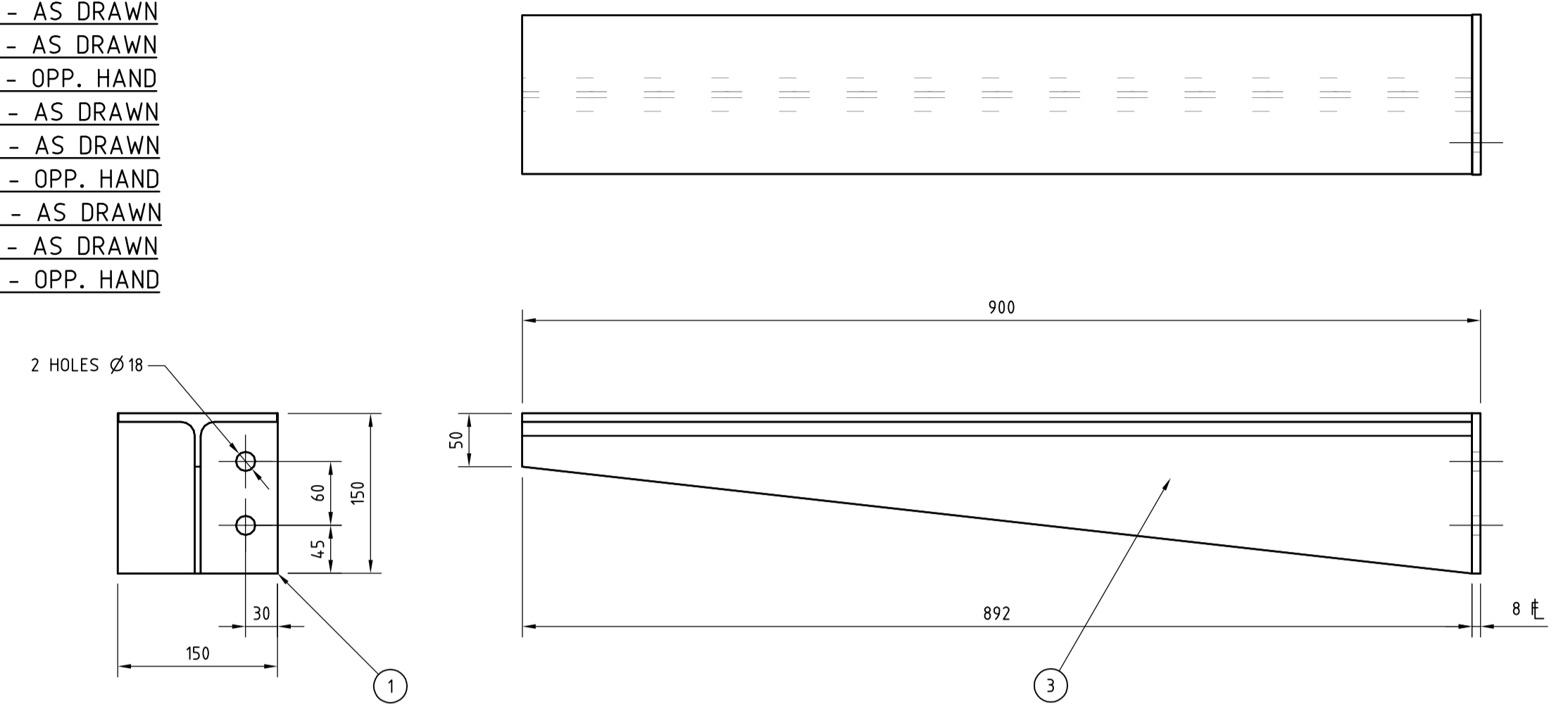
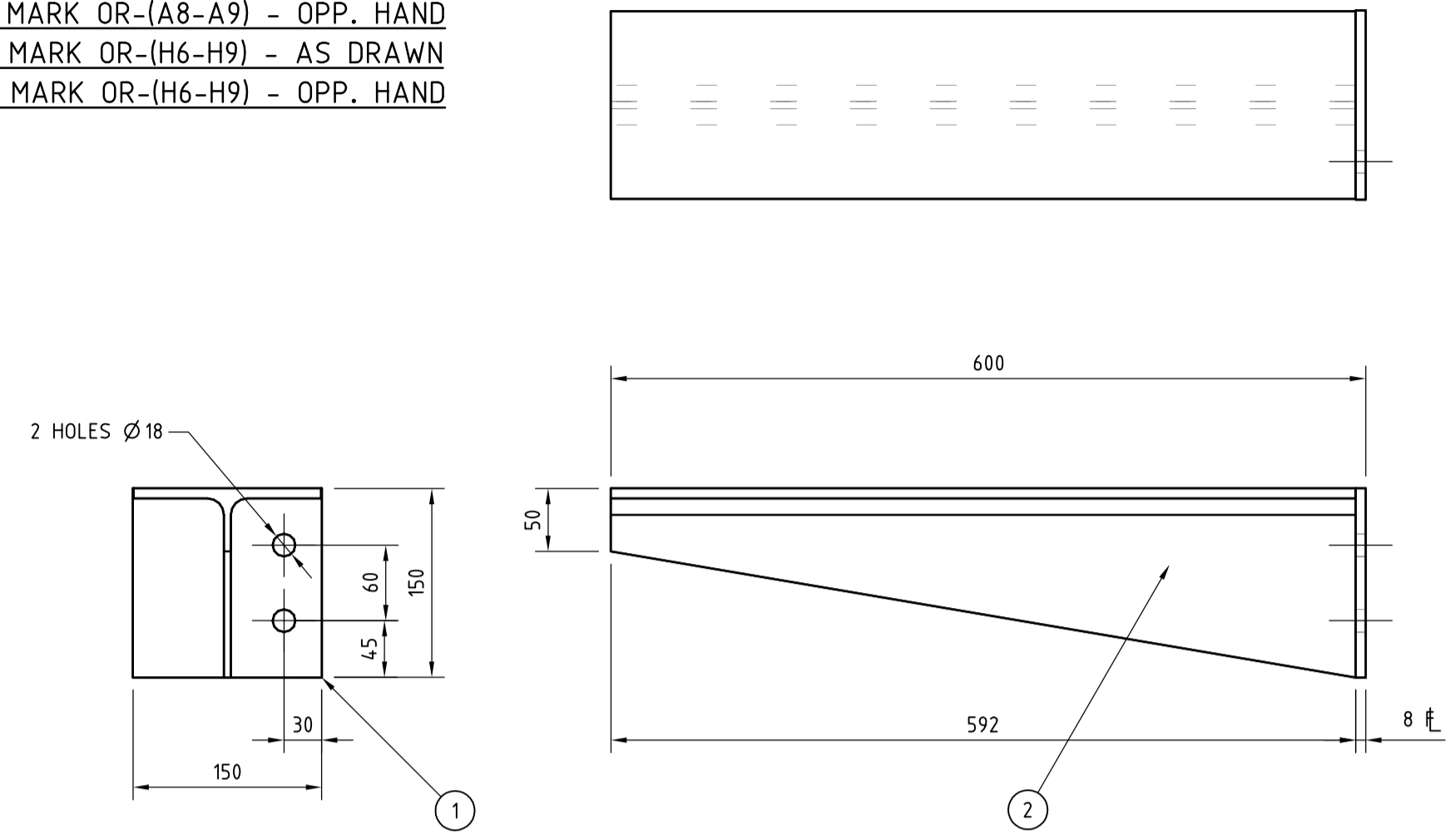

- 4 - OFF MARK OR-(R11-S11) - AS DRAWN
- 1 - OFF MARK OR-(N11-R11) - OPP. HAND
- 5 - OFF MARK OR-(N11-R11) - AS DRAWN
- 1 - OFF MARK OR-(L11-N11) - OPP. HAND
- 6 - OFF MARK OR-(L11-N11) - AS DRAWN

- 5 - OFF MARK OR-(E6-H6) - AS DRAWN
- 5 - OFF MARK OR-(H6-L6) - AS DRAWN

CALCULATED MASS: 1022.5 kg

NOTE:
THE MAIN OUTRIGGER IS CUT FROM A 310UB32.0.
2 OUTRIGGERS OF THE SAME LENGTH CAN BE CUT FROM A SINGLE 310UB32.0. FABRICATOR TO CHECK.

ITEM	DESCRIPTION	MATERIAL	FINISH	CALC. MASS	QTY
6	130 x 8 FLAT BAR - 142 LONG	MILD STEEL	AS PER SPEC.	1.1 kg	27
5	310UB32.0 - 1267 LONG	MILD STEEL	AS PER SPEC.	19.5 kg	10
4	310UB32.0 - 1124.5 LONG	MILD STEEL	AS PER SPEC.	17.2 kg	17
3	310UB32.0 - 892 LONG	MILD STEEL	AS PER SPEC.	12.4 kg	35
2	310UB32.0 - 592 LONG	MILD STEEL	AS PER SPEC.	8.2 kg	14
1	150 x 8 FLAT BAR - 150 LONG	MILD STEEL	AS PER SPEC.	1.4 kg	49

REV	BY	DATE	A.R.N.	DESCRIPTION
0	W	11-09-07	A7-0023	FOR APPROVAL
2	W	10-10-07	A7-0055	REVISED AS PER A.R.N. - FOR APPROVAL

WAI Engineering
2 Cumberland Street
Blacktown, NSW, 2148
Phone: 0418 203 229 - A/H: (02) 9671 5873 - Fax: (02) 9622 0450
e-mail: support@wai.com.au

The information contained on this drawing is subject to Copyright protection. © Copyright WAI Engineering.

DRAWN TO AS 1100	SCALE (A1)	1:5	CLIENT / PROJECT	RESIDENCE
CHECKED	DRAWN	W	TITLE	STRUCTURAL STEELWORK BUILDING STRUCTURE OUTRIGGER DETAILS #1
APPROVED	DESIGN ENG.		DRAWING No.	A7182002
			CLIENT CODE	TIE-001
			JOB No.	A718
			AutoCAD FILENAME	A7182000.DWG

798 mm

FOR CONSTRUCTION